

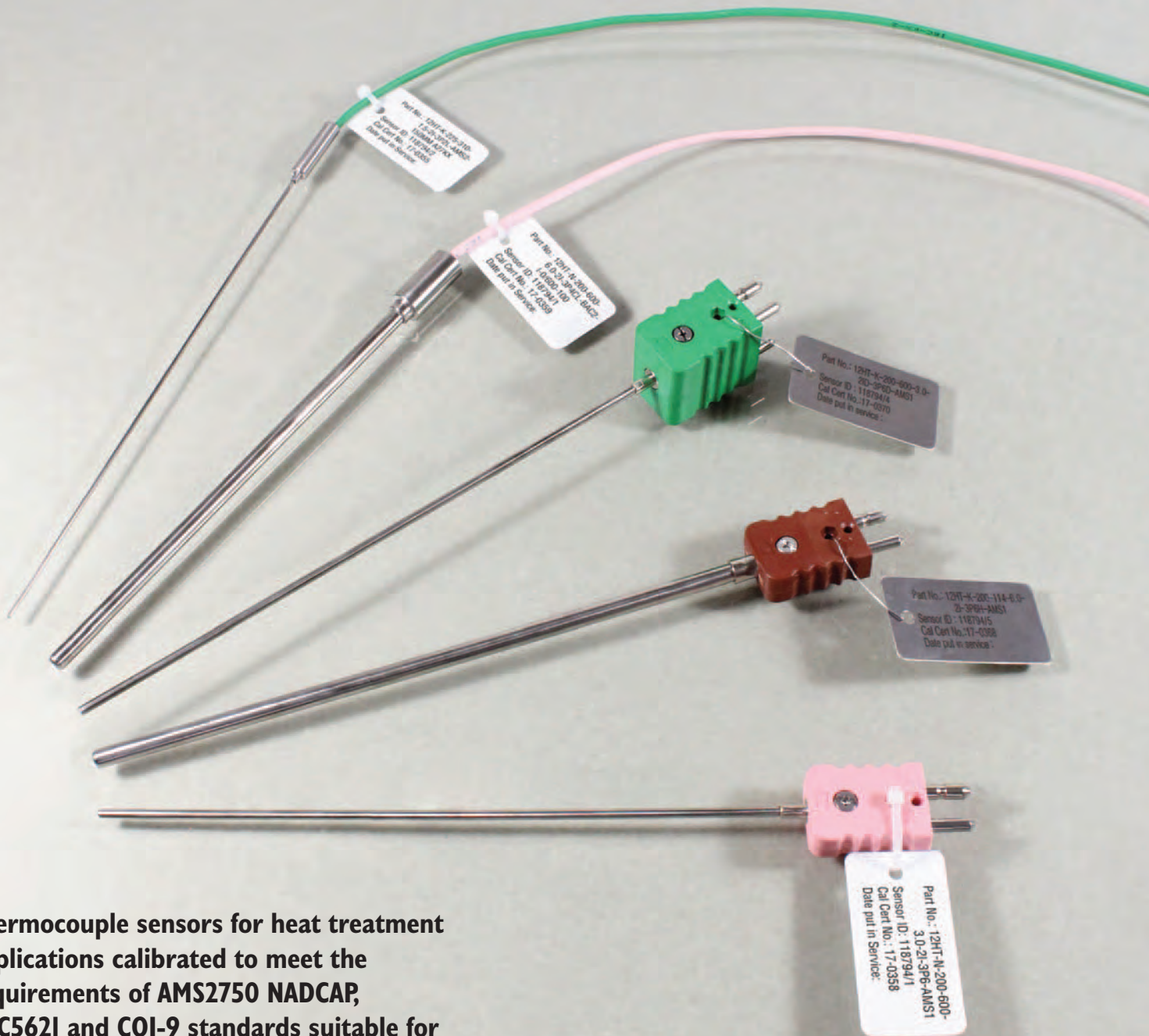

Calibrated Thermocouples for Heat Treatment Applications - Type 12HT



Thermocouple sensors for heat treatment applications calibrated to meet the requirements of AMS2750 NADCAP, BAC562I and CQI-9 standards suitable for use in Temperature Uniformity Surveys (TUS), System Accuracy Tests (SAT) and as Control, Monitoring and Load Sensors

Type 12HT Calibrated Heat Treatment Thermocouples

Calibrated Mineral Insulated Thermocouples

Our range of **AMS2750 NADCAP, BAC5621 or CQI-9 Compliant** mineral insulated thermocouples are designed to meet the high quality and accuracies demanded for heat treatment applications within the Aerospace industry. Through careful material selection and a comprehensive calibration program in our ISO17025 UKAS accredited laboratory, we can offer a wide range of sheath diameters and materials from stock with quick manufacture times. Their semi rigid construction allows them to be bent and formed to suit particular applications without impairing performance.

- Calibrated in line with **AMS2750 NADCAP, BAC5621 or CQI-9** requirements
- Suitable for use in **Temperature Uniformity Surveys (TUS), System Accuracy Tests (SAT)** or as **Control, Recording & Monitoring and Load sensors**
- **Batch calibration certificate supplied as standard**
- **Sensors are individually tagged and numbered for full traceability**
- Available in thermocouple types **N, K, T and J**
- **Wide range of sheath diameters and materials**

**AMS2750 NADCAP,
BAC5621 or CQI-9
certified**

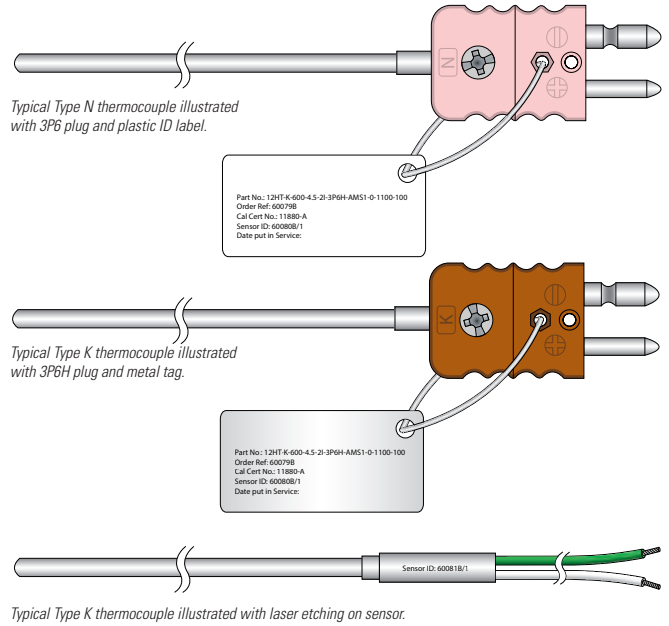

SECTION 1	Thermocouple Type	Temperature Range	
		(continuous)	(short term)
N	Nicrosil vs Nilcil	0°C to +1200°C	-270 to +1300°C
K	Nickel Chromium vs Nickel Aluminium	0°C to +1100°C	-180 to +1350°C
T	Copper vs Constantan	-185°C to +400°C	-250 to +400°C
J	Iron vs Constantan	+50°C to +700°C	-180 to +750°C

SECTION 2	Sheath Specifications	Operational Properties	Maximum Temperature
600	Inconel 600* Nickel/Chromium/Iron alloy To BS 3074 : 1974, Werkstoff No : 2.4816	Used in severely corrosive atmospheres to elevated temperatures. Has good resistance to oxidation. Do not use in sulphur bearing atmospheres above 550°C.	1100°C
114	Nicrotherm D™ Nickel/Chromium/Silicon/Molybdenum 73/22/1.4/3	For high temperature Type 'K' and almost all Type 'N'. Very good high temperature strength. Excellent in oxidising, carburising, reducing and vacuum atmospheres. Do not use in sulphur containing atmospheres.	1250°C
310	Grade 310 Stainless Steel 25/20 Nickel/Chromium To BS 970 Part 4 : 1970	Good high temperature corrosion resistance and suitable for use in sulphur bearing atmospheres. Has high oxidation resistance which is maintained if subsequent manipulation is strictly limited.	1100°C
321	Grade 321 Stainless Steel 18/8/1 Nickel/Chromium/Titanium Stabilised To BS 970 Part 4 : 1970	Very good corrosion resistance throughout the operating temperature range. Suited to a wide range of industrial applications. High ductility.	800°C

SECTION 3	Sheath Diameter (mm)	Sheath Diameter (inches)
	1.6mm (1/16")	0.063"
	2.0mm	0.079"
	3.0mm	0.118"
	3.2mm (1/8")	0.125"
	4.5mm	0.177"
	6.0mm	0.236"
	6.35mm (1/4")	0.250"
	8.0mm	0.315"

SECTION 4	Types of Sensing Junction	
2I		Insulated The hot (measuring) junction is insulated from the sheath and this gives a floating output with a typical insulation resistance in excess of 100 megohms. Enter 2I for simplex or 2ID for duplex.
2ID		

SECTION 5	Tagging	
PL		Plastic ID Label Rated 70°C. For use with all end seals.
ML		Laser Etched Metal Tag For use with all end seals above 250°C.
EL		Laser Etching on Sensor Laser etch of serial number. This can be instead of or in addition to either of the options above.

SECTION 6	Calibration Accuracies			
	Standard	Accuracy Supplied	Permitted Applications	Certification
AMS1	AMS2750	±1.1°C or 0.4% of reading (whichever is greater). End to end deviation of material batch no greater than 1.1°C	Temperature Uniformity Survey (TUS) System Accuracy Test (SAT) Control, Monitoring & Recording (Class 1 & 2)	An in-house 3 page report for the start/end of batch, with all the information NADCAP auditors require (please refer to the Calibration Details section for a detailed explanation). The temperature ranges of each thermocouple type are listed below.
BAC2	BAC5621	±1.1°C <538°C or 0.4% of reading >538°C. End to end deviation of material batch no greater than 0.6°C	Secondary/Field Test Sensor	Types K and N: 0-1200°C Type T: 0-300°C Type J: 0-700°C
CQI1	CQI-9	±1.1°C or 0.4% of reading (whichever is greater). End to end deviation of material batch no greater than 1.1°C	Temperature Uniformity Survey (TUS) System Accuracy Test (SAT) Control, Monitoring & Recording (Class 1 & 2) Load	Please note: UKAS calibration and individual point calibration is available on request. Please contact us for details.

Calibrated Heat Treatment Thermocouples Type 12HT

SECTION 7		Types of End Seal Configuration					
Diagram		Specification		Diagram		Specification	
3P1		Internal Seal with Bare Conductors for all sheath diameters		3P6		Standard 2-pin (round) Plug for sheath diameters between 1.5mm & 8.0mm	
		3P1	Maximum end seal temperature 135°C			3P6	Plug rated to 220°C
3P1B		3P1B	Maximum end seal temperature 300°C			3P6H	Plug rated to 300°C
						3P6UH	Plug rated to 425°C
						3P6C	Plug rated to 600°C
3P2L		Crimp on Stainless Steel Pot Seal for sheath diameters up to 3.0mm		3P6M		Miniature 2-pin (flat) Plug for sheath diameters between 1.5mm & 3.0mm	
		3P2L	Pot Seal rated to 135°C			3P6M	Plug rated to 220°C
3P2LA		3P2LA	Pot Seal rated to 235°C			3P6MH	Plug rated to 300°C
3P2LB		3P2LB	Pot Seal rated to 300°C			3P6MUH	Plug rated to 425°C
			see section 9 if extension leads are required			3P6MC	Plug rated to 600°C
3P2TRL		Stainless Steel Pot Seal with Anti Chafe Spring for sheath diameters up to 3.0mm		3P7		Standard 2-pin (round) Socket for sheath diameters between 1.5mm & 8.0mm	
		3P2TRL	Pot Seal rated to 135°C			3P7	Socket rated to 220°C
3P2TRLA		3P2TRLA	Pot Seal rated to 235°C			3P7H	Socket rated to 300°C
3P2TRLB		3P2TRLB	Pot Seal rated to 300°C			3P7UH	Socket rated to 425°C
			see section 9 if extension leads are required			3P7C	Socket rated to 600°C
			<i>* It is unlikely that any benefit would be derived from specifying this type of pot seal with the standard 100mm tails.</i>				
3P4CL		Crimp on Stainless Steel Pot Seal for sheath diameters between 3.0mm & 8.0mm		3P7M		Miniature 2-pin (flat) Socket for sheath diameters between 1.5mm & 3.0mm	
		3P4CL	Pot Seal rated to 135°C			3P7M	Socket rated to 220°C
3P4CLA		3P4CLA	Pot Seal rated to 235°C			3P7MH	Socket rated to 300°C
3P4CLB		3P4CLB	Pot Seal rated to 300°C			3P7MUH	Socket rated to 425°C
			see section 9 if extension leads are required			3P7MC	Socket rated to 600°C
3P4CTRL		Stainless Steel Pot Seal with Anti Chafe Spring for sheath diameters between 3.0mm & 8.0mm		3P6D		Standard DUPLEX 2-pin (round) Plug for sheath diameters 6.0mm & 8.0mm	
		3P4CTRL	Pot Seal rated to 135°C			3P6D	Plug rated to 220°C
3P4CTRLA		3P4CTRLA	Pot Seal rated to 235°C			3P6DH	Plug rated to 300°C
3P4CTRLB		3P4CTRLB	Pot Seal rated to 300°C			3P6DUH	Plug rated to 425°C
			see section 9 if extension leads are required			3P6DC	Plug rated to 600°C
			<i>* It is unlikely that any benefit would be derived from specifying this type of pot seal with the standard 100mm tails.</i>				

SECTION 8		Extension Cables					
Diagram		Specification		Diagram		Specification	
A30		HR PVC Flat Twin (105°C) One pair of 7/0.2mm stranded conductors HR PVC insulated. Pair laid flat and HR PVC sheathed overall.		C20		Fibreglass Flat Twin (480°C) One pair of solid 1/0.5mm conductors. Cores double glass fibre lapped, braided and silicone varnished. Pair laid flat, glass fibre braided overall and silicone varnished.	
A27		HR PVC Twisted Pair with Screen (105°C) One pair of 7/0.2mm stranded conductors HR PVC insulated. Pair twisted, screened with Mylar® aluminium tape and drain wire. HR PVC sheathed overall.		C40		Fibreglass Flat Twin (480°C) One pair of 7/0.2mm stranded conductors double glass fibre lapped, braided and varnished. Pair laid flat, glass fibre braided and varnished.	
B20		PFA Flat Twin (250°C) One pair of 1/0.5mm solid conductors PFA insulated. Pair laid flat. PFA sheathed overall.		C60		Fibreglass Flat Twin with Steel Braid (480°C) One pair of 7/0.2mm stranded conductors double glass fibre lapped, braided and varnished. Pair laid flat, glass fibre braided and varnished. Stainless steel wire braided overall.	
B50		PFA Flat Twin (250°C) One pair of 7/0.2mm stranded conductors PFA insulated. Pair laid flat. PFA sheathed overall.		M 1702		PVC 2-Pair - for Duplex Sensors (105°C) Two pairs of 7/0.2mm stranded conductors FR PVC insulated. Pairs twisted and individually screened with Mylar® aluminium tape with a drainwire. Pairs laid up and screened overall with Mylar® aluminium tape with a drainwire. FR PVC sheathed.	
B80		PFA Twisted Pair with Screen (250°C) One pair of 7/0.2mm stranded conductors PFA insulated. Pair twisted, screened with Mylar® aluminium tape and drain wire with a PFA sheath overall.		BM 0702		PFA 2-Pair - for Duplex Sensors (250°C) Two pairs of 7/0.2mm stranded conductors PFA insulated. Pairs twisted and bunched and screened with Mylar® aluminium tape with a drainwire. PFA sheathed.	

If no cable is required, leave this section of the order code blank and the sensor will be supplied with PFA tails. Other cables are available on request.

'HR' = Heat Resistant, 'FR' = Flame Retardant

Order Code - Example								
Style No.	Thermocouple Type (see section 1)	Sheath Length (in mm)	Sheath Material (see section 2)	Sheath Diameter (see section 3)	Sensing Junction (see section 4)	End Seal Termination (see section 7)	Extension Cable (see section 8)	Calibration Accuracy (see section 6)
12HT	- N	- 2000	- 600	- 3.0	- 2I	- 3P4CLA	- 1 MTR B50NX	- AMS1

Alternative Calibration Details (Optional)*		
UKAS (U) / In House (I)	Calibration Range (see section 6)	Interval / Custom Temperatures (in °C)
U	- 500/1200	- 100

Tagging Options		
Plastic ID Label (see section 5)	or Metal Tag Label (see section 5)	Etched on Sensor (see section 5)
PL	or ML	- EL

*See section 6 and page 4 for further details of our standard calibration report.

Type 12HT Calibrated Heat Treatment Thermocouples



Calibration Details

All 12HT sensors are supplied with a 3-page batch calibration report (shown left) over the following temperature ranges: Types K and N: 0-1200°C, Type T: 0-300°C and Type J: 0-700°C.

Calibration is performed in our ISO17025 approved laboratory and is fully traceable to NPL/NIST standards. The report is designed with the needs of the selected standard in mind and includes a list of calibrated equipment used, results for start/end/average of batch (figure 1), correction factors, start/end differential and graphical representation of the output curves (figure 2). All applicable standards are referenced in a conformity statement (figure 3).

Calibration reports are generated for each batch of sensors manufactured with a unique certificate number and the following order-specific information:

- Customer Name and Address
- Order Reference
- Coil Reference
- Coil Length
- Serial Number
- Description of Product
- Sensor Part Code

TC Ltd operate an extensive pre-testing calibration program. All of our mineral insulated cables used to manufacture the 12HT range are calibrated in our laboratory, all reels meeting the requirements of the AMS2750, BAC5621 & CQI-9 standards are stocked ready for quick manufacture with a 7/10 day typical lead time for completed sensors with calibration report.

If your application requires individual sensor calibration or uses custom temperatures not shown on the report, these requirements can be added to the 12HT part code as shown in the order code example below. We will then perform the custom calibration before despatch and amend the report accordingly. It is also possible to specify full UKAS calibration if required. Please contact one of our experienced sales engineers for more details.

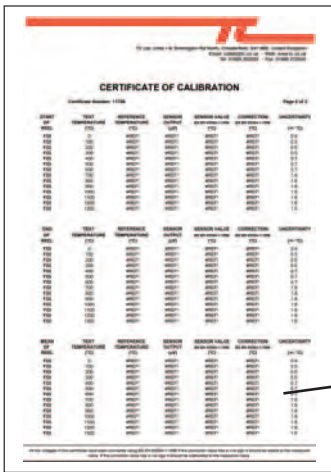

START OF REEL	TEST TEMPERATURE (°C)	REFERENCE TEMPERATURE (°C)	SENSOR OUTPUT (µV)	SENSOR VALUE BS EN 60584-1:1996 (°C)	CORRECTION BS EN 60584-1:1996 (°C)	UNCERTAINTY (+/- °C)
E93	0	0.18	10.2	0.39	-0.21	0.4
E93	100	99.60	2743.2	98.94	+0.66	0.6
E93	200	199.76	5874.4	198.83	+0.93	0.6
E93	300	300.01	9325.7	299.55	+0.46	0.6
E93	400	400.21	12970.2	399.91	+0.30	0.8
E93	500	500.42	16759.2	500.29	+0.13	0.8
E93	600	600.77	20648.7	600.91	-0.14	0.8
E93	700	700.39	24489.7	699.06	+1.33	1.6
E93	800	799.53	28380.7	798.12	+1.41	1.7
E93	900	899.31	32274.2	897.51	+1.80	1.7
E93	1000	1000.46	36222.4	999.15	+1.31	1.8
E93	1100	1100.51	40050.0	1099.03	+1.48	1.8
E93	1200	1199.45	43765.4	1197.82	+1.63	1.9

Figure 1: Example of sensor results table

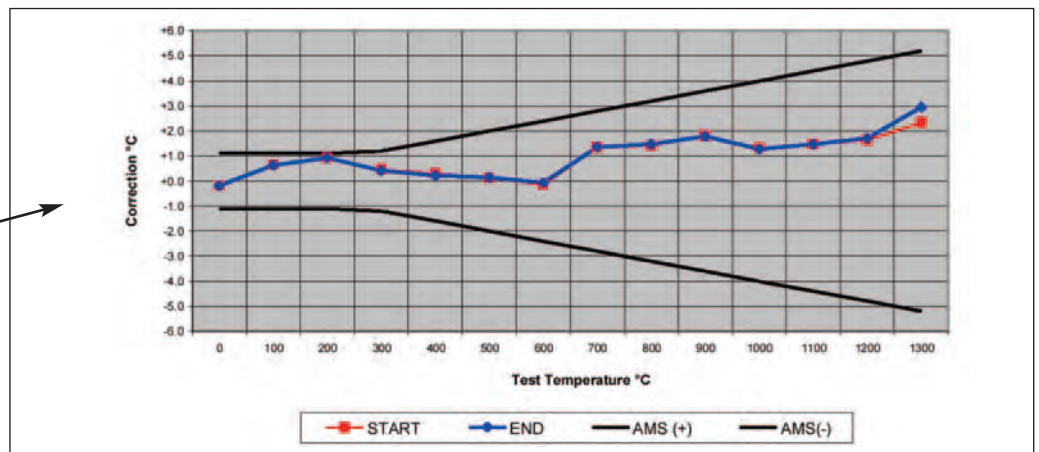
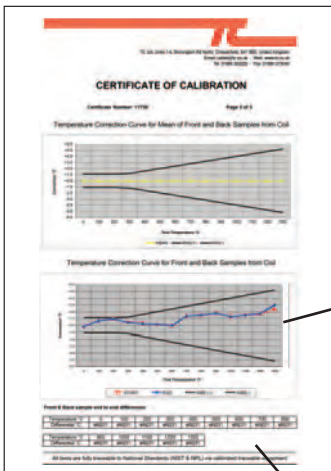

Figure 2: Example of sensor results graph

TC
 PO Box 130
 Uxbridge
 UB8 2YS
 United Kingdom
 Tel: 01895 252222
 International: +44 1895 252222
 Email: info@tc.co.uk
 Web: www.tc.co.uk

Front & Back sample end to end differences									
Temperature °C	0	100	200	300	400	500	600	700	800
Differential °C	-0.02	0.03	0.01	0.05	0.07	-0.02	-0.08	-0.02	-0.06
Temperature °C	900	1000	1100	1200	1300				
Differential °C	0.02	0.03	0.00	-0.08	-0.63				

All tests are fully traceable to National Standards (NIST & NPL) via calibrated traceable equipment

Figure 3: Example of deviation table and conformity statement